

2ª EDIZIONE



TR
TUTTORETTIFICHE®

NEWS

L'UNIONE VINCENTE STELLANTIS!

impegnati per raggiungere
le **emissioni zero**
di tutte le nostre **attività**

un gruppo eterogeneo di
400.000 donne e uomini di talento

la **soddisfazione** del cliente
guida l'**innovazione**

ampia offerta di **veicoli**
e **marchi iconici**

STELLANTIS

posizione consolidata in
**Europa, Nord America
e America Latina**

ampia offerta
di **veicoli
elettrificati**

spirito **agile**
e **competitivo**

presenza commerciale
in **oltre 130** mercati

presenza industriale
in **oltre 30** Paesi

Sono passati alcuni anni dal grande matrimonio PSA e FCA ma le aspettative sono tante per il gruppo STELLANTIS; Infatti il significato del logo che sigilla questa unione la dice tutta.

“Il logo rappresenta il ricco patrimonio delle due società fondatrici e la forza dell’insieme dei 14 marchi automobilistici del nuovo gruppo nonché la diversità di talento e know-

how dei suoi dipendenti in tutto il mondo” afferma un comunicato ufficiale rilasciato dal neo-colosso”.

Le radici del gruppo PSA Peugeot Société Anonyme risalgono al 1965, quando per la prima volta comparve questa sigla per indicare le società controllate dal marchio Francese. Nel aprile del 1976 il gruppo PSA sentì la necessità di rafforzare la propria reputazione, per

questo motivo subentrò la Citroen; Nonostante questa unione giovasse entrambe le case automobilistiche, c’è da ammettere che non fu subito rose e fiori. Ma come mai? Le caratteristiche e i valori delle due erano troppo contrastanti per far sì che la collaborazione portasse i frutti; da una parte Peugeot, solido e conservativo e dall’altra Citroen troppo innovativo per il mercato; poco dopo infatti quest’ultima si troverà a dover far i conti

con delle scelte fin troppo futuristiche che porteranno ad un crollo delle vendite.

Nel corso degli anni sono state svariate le alleanze con i diversi costruttori, ma tra quelle più importanti è impossibile non menzionare la collaborazione il con gruppo FCA.

CITROEN & PEUGEOT BENZINA

1000 cc

3 Cilindri diam.71

KITZM01

kit composto da: pistoni 0.50, bronzine banco e biella std, serie guarnizione motore completa

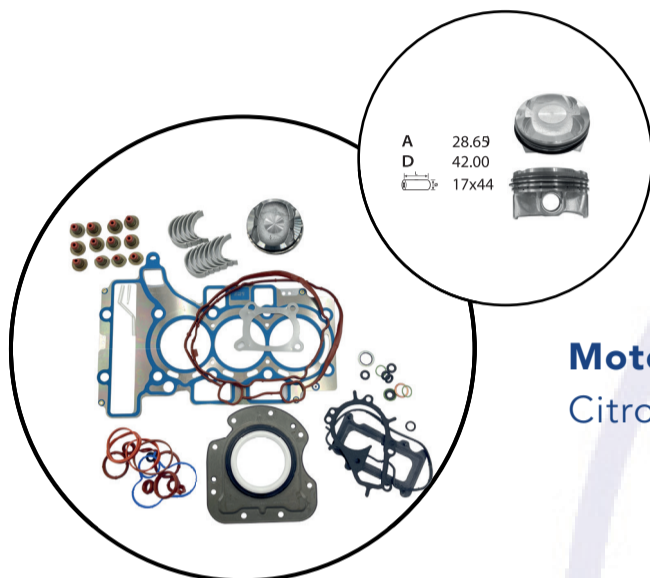

Motori:

Citroen - Peugeot: ZMZ, ZM01

1199 cc

3 Cilindri diam.75

KITHM01

kit composto da: pistoni 0.50, bronzine banco e biella std, serie guarnizione motore completa

Motori:

Citroen - Peugeot: HM01, HMY, HMZ, HMZ, HMR, HMM, HMP, HMU, HMT Opel: B12XE, D12XE, F12XE, F12XEL

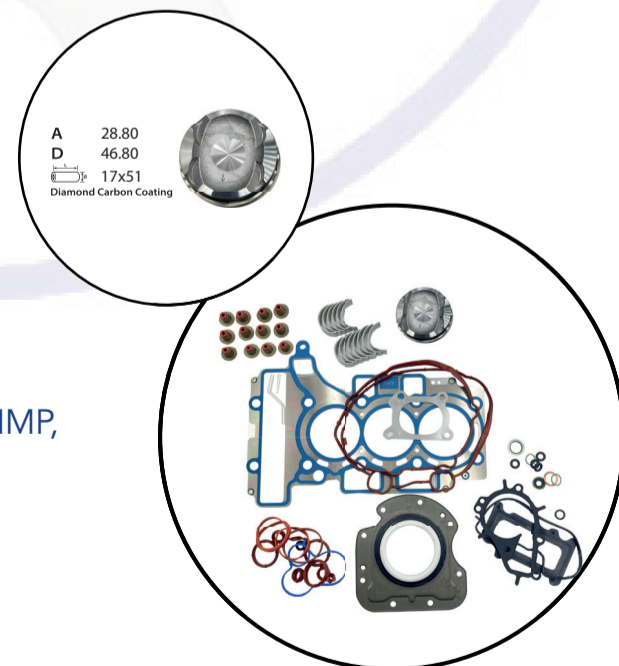

CITROEN & PEUGEOT BENZINA

1199 cc

3 cilindri diam.75

KITHN01

kit composto da: pistoni 0.50, bronzine banco e biella std, serie guarnizione motore completa

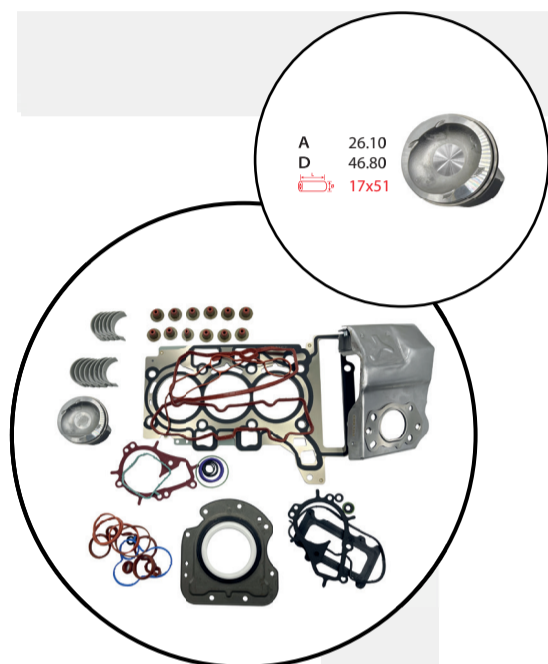

Motori:

Citroen - Peugeot: HN01, HNZ, HNP, HNV, HNS, HNY, HNE, HNK, HNN, HNP, HN05, HN11, HNL, HNM, HNR, HNT
Opel: D12XHT, D12XHL, B12XHT, F12XHT, F12XHL, F12XHP

1199 cc

3 cilindri diam.75

KITHN01/1

kit composto da: pistoni 0.50, bronzine banco e biella std, serie guarnizione motore completa

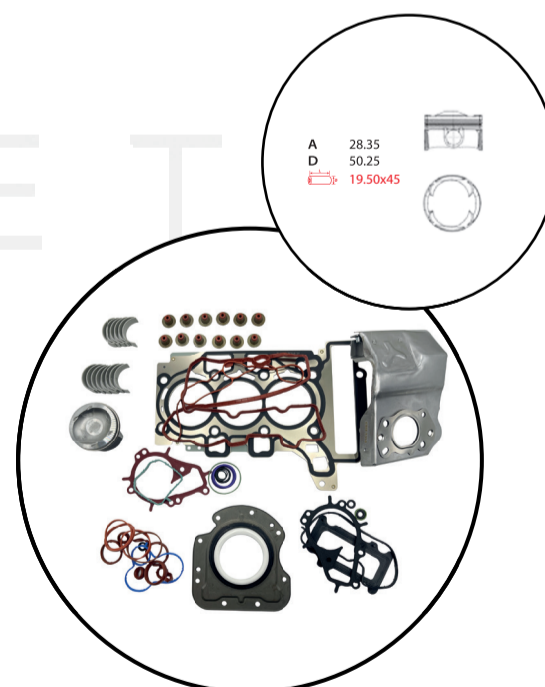

Motori:

Citroen - Peugeot: HN01, HNZ, HNP, HNV, HNS, HNY, HNE, HNK, HNN, HNP, HN05, HN11, HNL, HNM, HNR, HNT
Opel: D12XHT, D12XHL, B12XHT, F12XHT, F12XHL, F12XHP



FIAT DIESEL

1.3 mjt 16v

4 cilindri diam.69,60

KIT1300MJT

UNIFICATO

kit composto da: pistoni 0.40, bronzine banco e biella std, serie guarnizione motore con guarnizione testa due fori

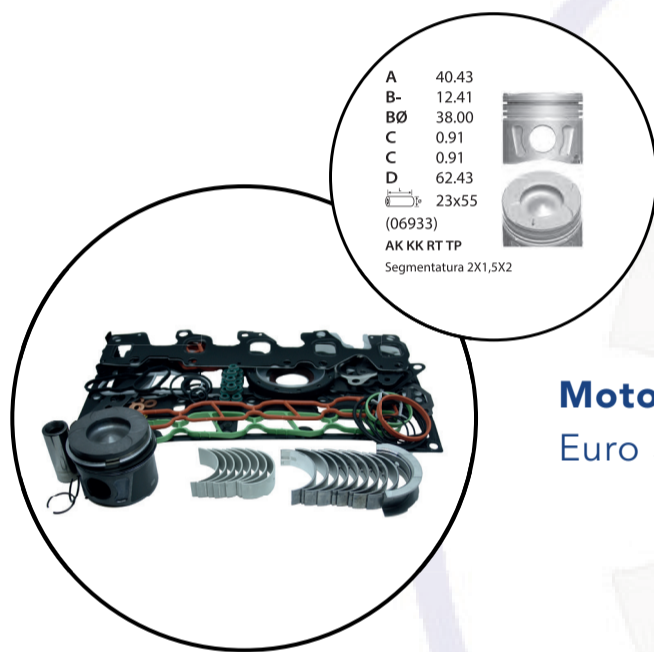

Motori:

Euro 3, 4, 5, 6 - 75, 90, 95 Cv

A richiesta possibilità di fornire il kit proposto con i pistoni 0.60, bronzine banco e biella 0.25 - 0.50 e guarnizione testa un foro



A.55232996 **Versione senza sensore**
A.55233278 **Versione con sensore**



01.18289 22,45x6x109,2
01.18290 22,50x6x109,2

01.18255 22,00x6x109,2
01.18256 21,80x6x109,3



08-425600-00 2,0 - 1,5 - 2,0
08-425600-00/2 1,5 - 1,5 - 2,0



26.4285

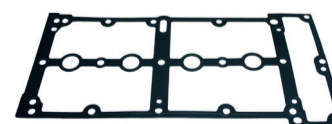

A.73500063

FIAT

FIAT DIESEL

1.3 mjt 16v

4 cilindri diam.69,60

KIT1300MJT/1

UNIFICATO

kit composto da: pistoni 0.40, bronzine banco e biella std, serie guarnizione motore con guarnizione testa due fori

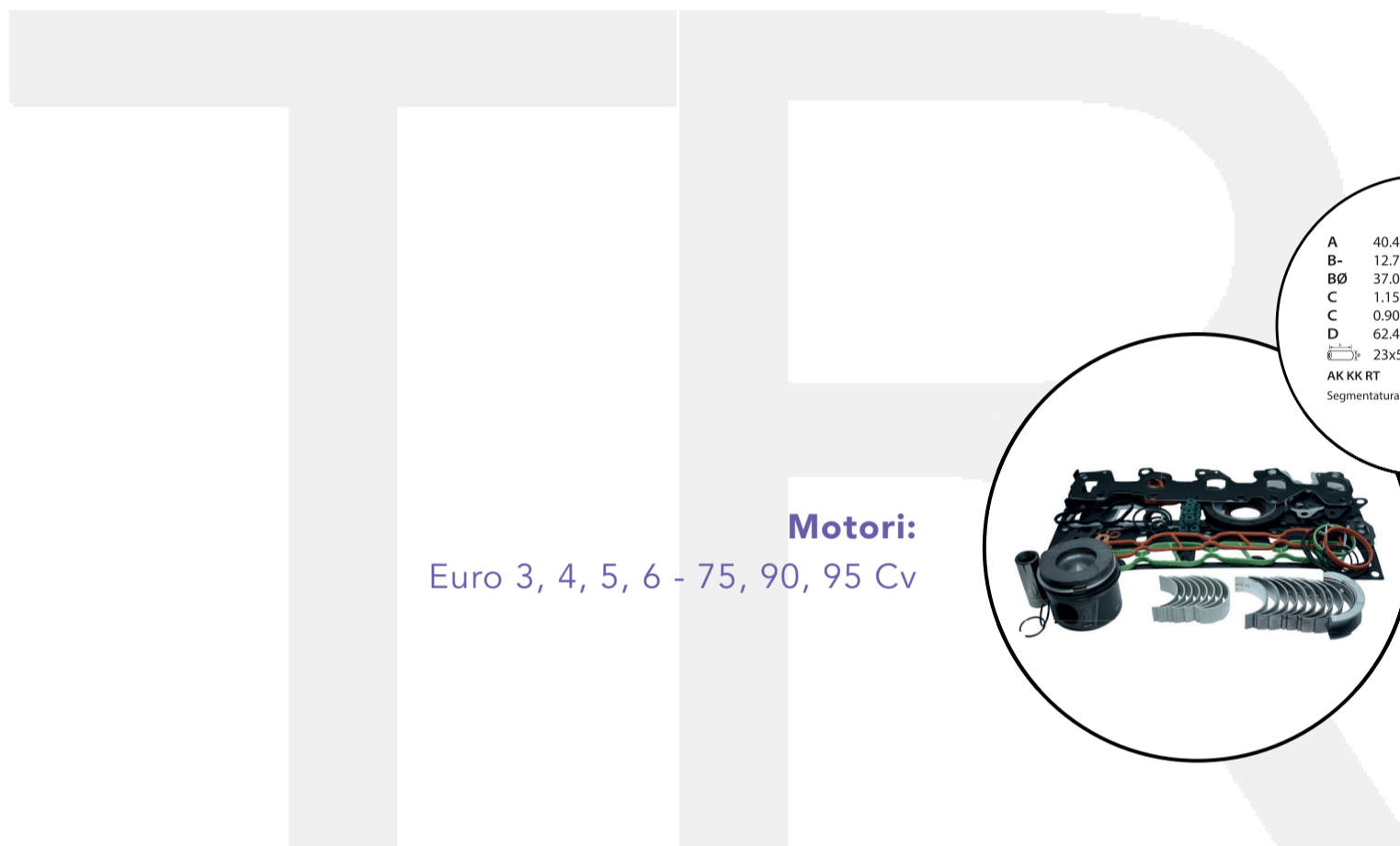

Motori:
Euro 3, 4, 5, 6 - 75, 90, 95 Cv

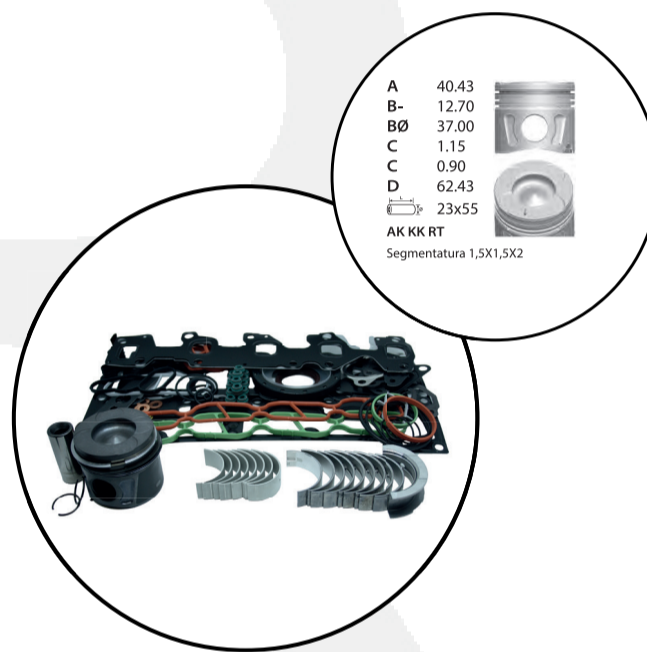

A richiesta possibilità di fornire il kit proposto con i pistoni 0.60, bronzine banco e biella 0.25 - 0.50 e guarnizione testa un foro



10.1300MJT



A.73500417



A.46475925



A.73501138



HBS353



11.46823507 **Lato aspirazione**



11.46823508 **Lato scarico**

FIAT

FIAT IVECO DIESEL

2.3 mjt 16v €4/5

4 cilindri diam.88

KITF1AE€4/5 **BASAMENTO GHISA, SOTTOBASAMENTO GHISA**

kit composto da: pistoni 0.40, bronzine banco e biella std, serie guarnizione motore senza guarnizione testa

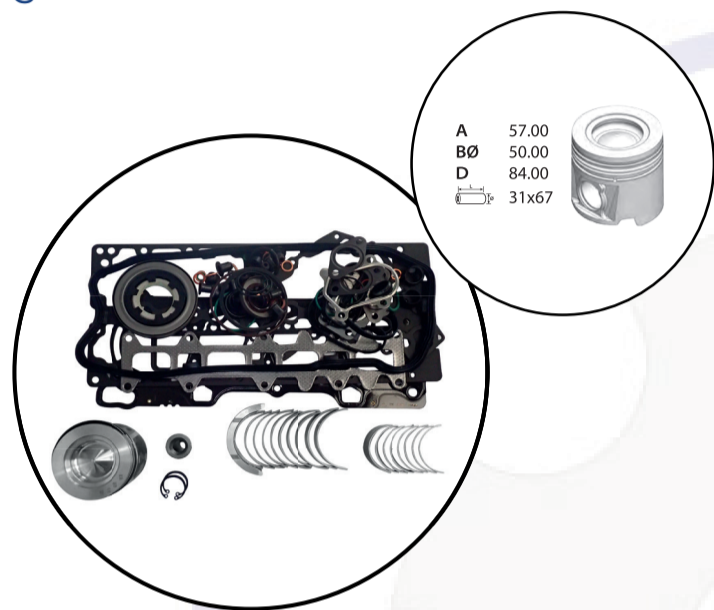

A 57.00
BØ 50.00
D 84.00
31x67



Motori:

F1AE0481A, F1AE0481B, F1AE0481F, F1AE0481D,
F1AE0481N, F1AE0481G, F1AE0481V,
F1AE3481A, F1AE3481B, F1AE3481C,
F1AE3481D, F1AE3481E, F1AFL411B, F1AFL411C

2.3 mjt 16v €6

4 cilindri diam.88

KITF1AE€6 **BASAMENTO GHISA, SOTTOBASAMENTO ALLUMINIO**

kit composto da: pistoni 0.40, bronzine banco e biella std, serie guarnizione motore senza guarnizione testa

Motori:

F1AE3481D, F1AE3481E, F1AEFL411A,
F1AGL411B, F1AGL411D, F1AGL411G,
F1AGL411H, F1AGL411L

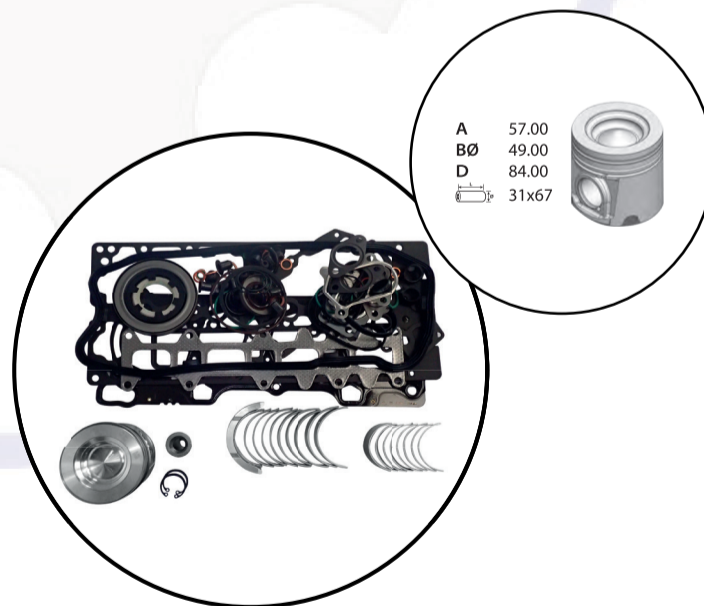

A 57.00
BØ 49.00
D 84.00
31x67



A.504074464



10.1801



08.23 BOCCOLE PIEDE BIELLA 2.3
08.30 BOCCOLE PIEDE BIELLA 3.0



01.18253 30x6x120,40
01.18254 30x6x120,35

IVECO

LAND ROVER / JAGUAR

2.0 Diesel

4 cilindri diam.83

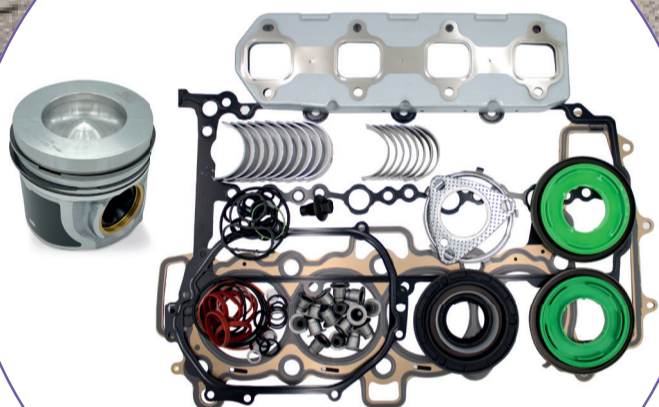

10.204D4/1

10.204D4



A richiesta reperibili le versioni DTD - DTH - DTA



02.3076 82,60 x 87,50 x 154 Bordo 89 x 4,50



01.52084 27,30 x 5,5 x 100,33
01.52085 25,65 x 5,5 x 100,35



17.204D4



23.EVOSTD Ø 83 - 1,5 - 1,75 - 1,5

VERSIONE 204 DTD - DTH

KITEVOSTD

Kit motore composto da pistoni std, bronzine banco e biella std e serie guarnizione motore completa

KITEVO050

Kit motore composto da pistoni 0.50, bronzine banco e biella std e serie guarnizione motore completa

VERSIONE 204 DTA

KITEVOSTD/1

Kit motore composto da pistoni std, bronzine banco e biella std e serie guarnizione motore completa

KITEVO050/1

Kit motore composto da pistoni 0.50, bronzine banco e biella std e serie guarnizione motore completa

A richiesta possibilità di fornire i kit proposti con bronzine banco e biella 0.10 - 0.20

PSA STELLANTIS BENZINA

1.4 -1.6 cc 16v

4 cilindri diam.77

kit composto da: pistoni 0.50, bronzine banco e biella std, serie guarnizione motore completa

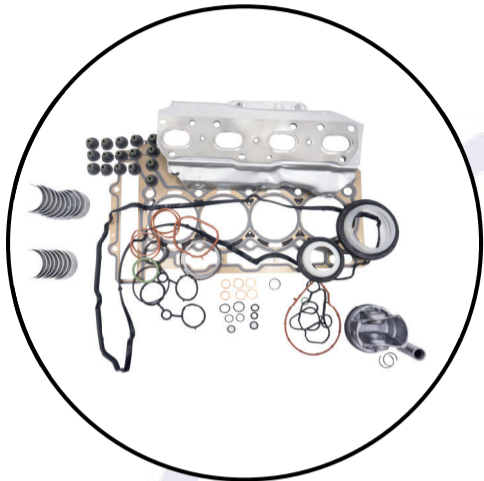

KIT8001

Motori:

Citroen - Peugeot: 5FD, 5FK, 5FS, 5FH EP6D
Mini: N12B16A , N14B16A, N14B16C



KITN14B16C

Motori:

Citroen - Peugeot: N5F5, 5FK, 5FS
Mini: N14B16C

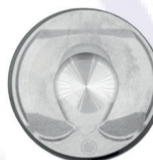

KITN18B16A

Motori:

Mini: N13B16A, N18B16A



KITN12B14A

Motori:

Citroen - Peugeot: 8FS, 8FN, 8FR, 8F02, 5FW, 5FK, 5FP, EP3
Mini: N12B14A, N12B16A

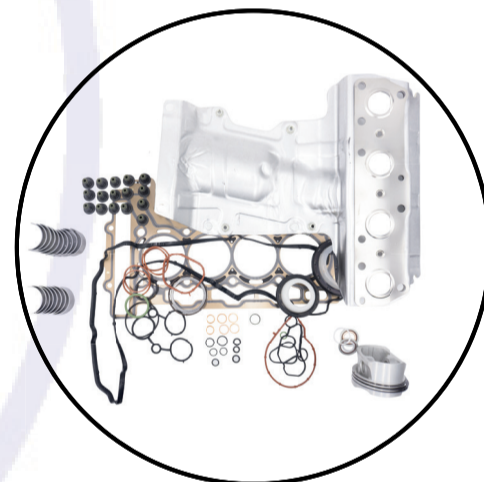

23.N14B16A Ø 77 1,2 - 1,5 - 2,0

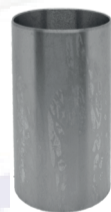

02.3002 76x79x135 Bordo 82,10x5
02.3024 76x79x135 S.B.



01.80005 30x5x97
01.80006 25,10x5x110,80



05.N14B16A

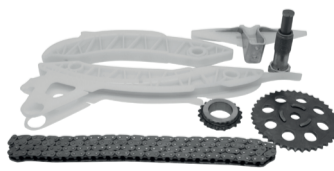

10.8003



10.8002



PSA STELLANTIS DIESEL

2.0 cc tdi 16v

4 cilindri diam.84

KIT2.0ECOBLUE

kit motore composto da: pistoni 0.50, bronzine banco e biella std, serie guarnizione motore senza testa

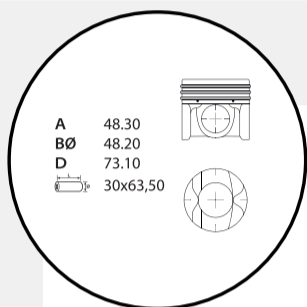

Motori:

Ford: YLCB, YLDA, YLRA, YMCC, YMFA, YMFB, YMHA, YMRA, YNCA, YNFA, YNFB, YNRA, BLRA, BKFB, BCCC, BKFD, BKRB, BLFA, BJRA, BJRB, BLFD, BLRB, BLHA, BLFC, BKFA, BKFC, BKRA, BCCD, BJFA, BJFB, BJFC, BJFD

2.0 cc tdi 16v

4 cilindri diam.85

KITAH03

kit motore composto da: pistoni 0.50, bronzine banco e biella std, serie guarnizione motore senza testa

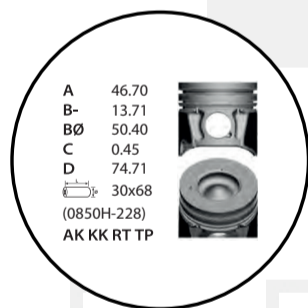

Motori:

Citroen - Peugeot: AH03, AHE, AHF, AHH, AHJ, AHK, AHN, AHP, AHR, AHU, AHU, AHV, AHW, AHX, EHS, EHT, EHW, EHV

Ford: T7CA, T7CC, T7CD, T7CE, T7CF, T7CI, T7CJ, T7CK, T7CL, T7CN, T7CP, T7CQ, T7DA, T7DB, T7DC, T7DD, T7MA, T7MB, T8CA, T8CB, T8CC, T8CD, T8CG, T8CH, T8CI, T8CJ, T8CL, T8DA, T8DE, T8MA/ T8MB, T9CA, T9CB, T9CC, UFCA, UFCB, XRMA, XRMB

Opel: D20DTM, D20DTL, D20DTR

Toyota: 4WZ-FHV, 4WZ-FTV



15.4HU/1



05.AH03



PSA STELLANTIS DIESEL

2.2 cc tdi 16v

4 cilindri diam.86

KIT4HU

kit composto da: pistoni 0.50, bronzine banco e biella std, serie guarnizione motore senza testa

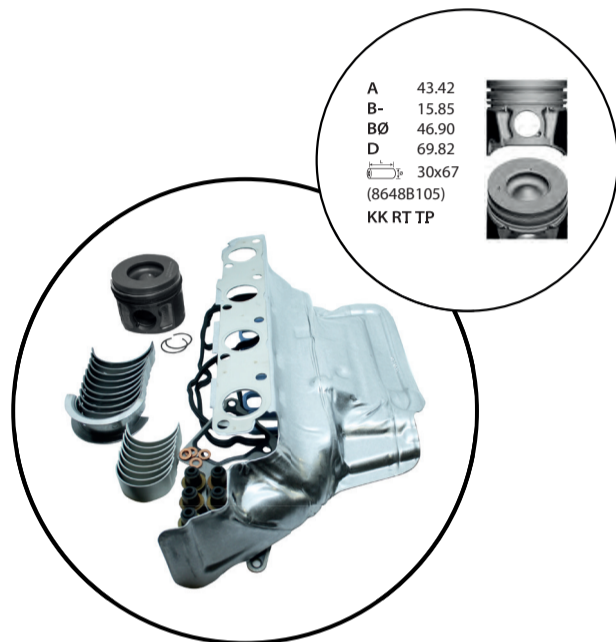

Motori:

Ford: PGFA, PGFB, SRFA, QVFA, P8FA, SRFB, SRFD, P8FB, QWFA, DT224, PGFA, QWFA, SRFA, SRFB, SRFB, SRFC, 5RFD, SRFE, CYFA, CYFB, CYFC, CYFD, DRFA, DRFB, DRFC, DRFD, DRFE, UHFA, UHFB, UHFC
Fiat, Citroen, Peugeot: 4HU, 4HV

2.2 cc tdi 16v

4 cilindri diam.86

KIT4HU48

kit composto da: pistoni 0.50, bronzine banco e biella std, serie guarnizione motore senza testa

Motori:

Ford: PGFA, PGFB, SRFA, QVFA, P8FA, SRFB, SRFD, P8FB, QWFA, DT224, PGFA, QWFA, SRFA, SRFB, SRFB, SRFC, 5RFD, SRFE, CYFA, CYFB, CYFC, CYFD, DRFA, DRFB, DRFC, DRFD, DRFE, UHFA, UHFB, UHFC
Fiat, Citroen, Peugeot: 4HU, 4HV



PSA STELLANTIS DIESEL

2.2 cc tdi 16v

4 cilindri diam.86

KIT4H03

kit composto da: pistoni 0.50, bronzine banco e biella std, serie guarnizione motore senza testa



Motori:

Ford: CYFA, CYFB, CYFC, CYFD, CYFF, CYFG, DRRB, GBJA, QJBA, QJBB, QJBC, QJBD, CVRB, CYRC, DRRD, USRA, USRB
 Fiat, Citroen, Peugeot: 4H03

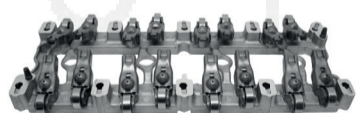

17.1214/2



15.2001



15.4HU



15.4HU/2



17.4HU



10.2003 2.2 cc



01.20253 29,8x7x122,2
 01.20254 25,7x7x122,2



05.4HU

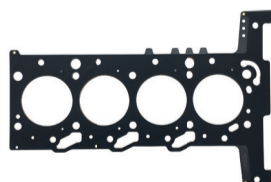

26.TC24HU 2 Fori
 26.TC34HU 3 Fori



11.2025
 11.2026



PSA STELLANTIS DIESEL

2.2 cc tdi 16v

4 cilindri diam.86

KIT4H03/1

kit composto da: pistoni 0.50, bronzine banco e biella std, serie guarnizione motore senza testa



A 83.42
B- 16.17
BØ 49.04
D 74.82
30x67
(08683-607)
AK KK RT TP



Motori:

Ford: QJBA, USRB, CYRC, DRRC, CVRA, CYRA, QJBC, DRRB, DRRD, GBJA, QJBB, CVRB, CVRC, CYRE, DRRR, QJBD, USRA
Land Rover: DT224



26.TC3CVRA 3 Fori



10.2002 2.4 cc

2.4 cc tdi 16v

4 cilindri diam.89,90

KITH9FB

kit composto da: pistoni 0,50, bronzine banco e biella std, serie guarnizione motore completa

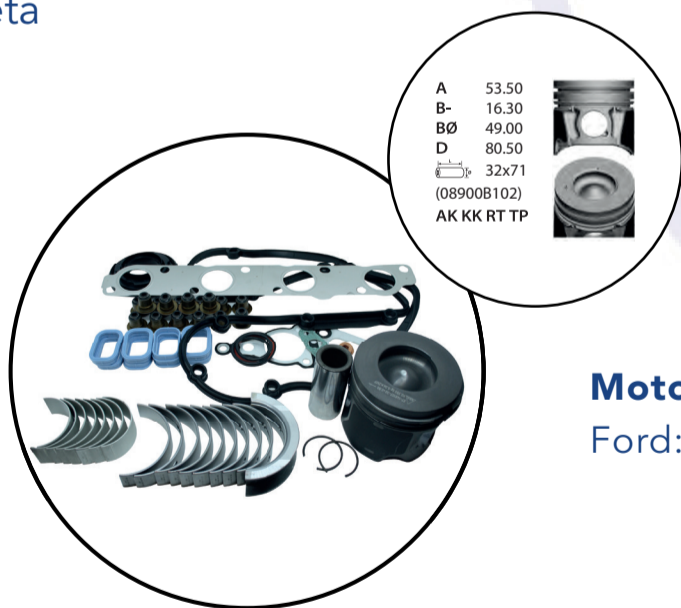

A 53.50
B- 16.30
BØ 49.00
D 80.50
32x71
(08900B102)
AK KK RT TP



Motori:

Ford: H9FB, JXFA, JXFC, PHFA, PHFC



11.2029
11.2030

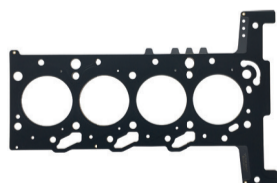

AA5960 3 Fori



HBS296



10.2002 2.4 cc



15.4HU



15.4HU/2



17.4HU



RENAULT DIESEL

1.5 cc

4 cilindri diam.76

KIT1K9K

kit composto da: pistoni 0.50, bronzine banco e biella std, serie guarnizione motore completa

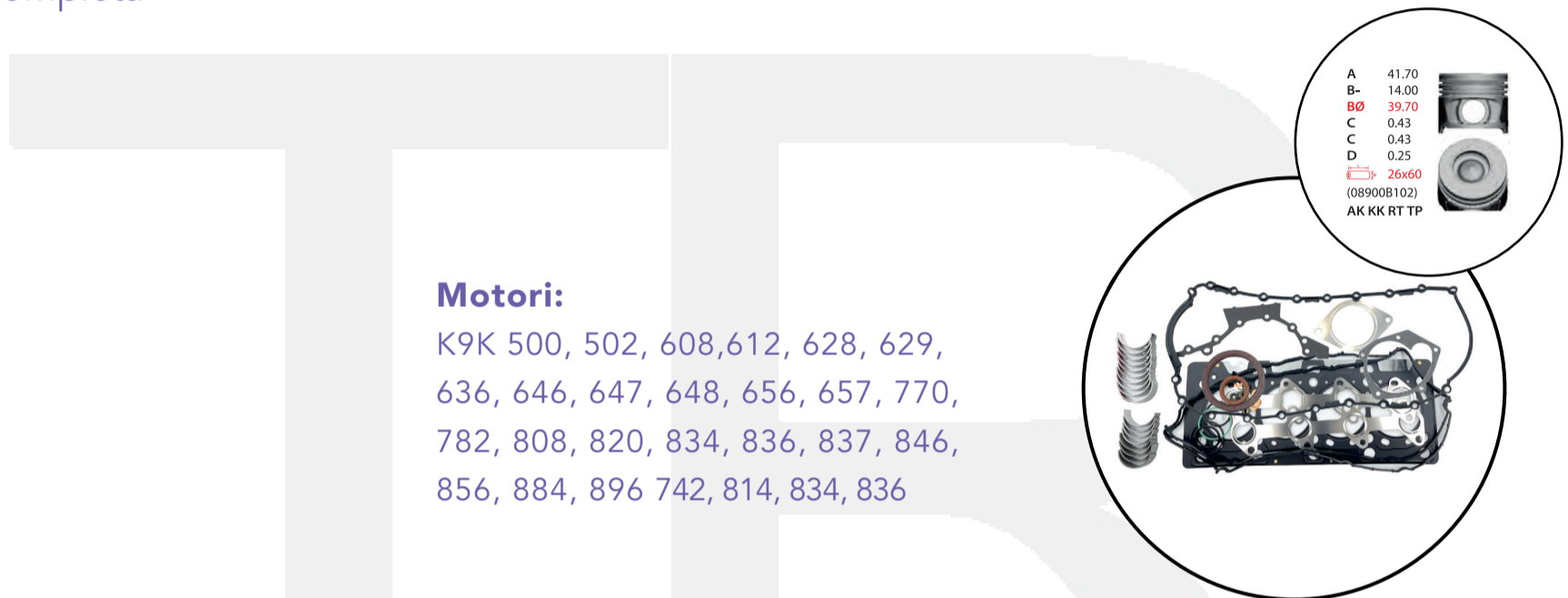

1.5 cc

4 cilindri diam.76

KIT2K9K

kit composto da: pistoni 0.50, bronzine banco e biella std, serie guarnizione motore completa

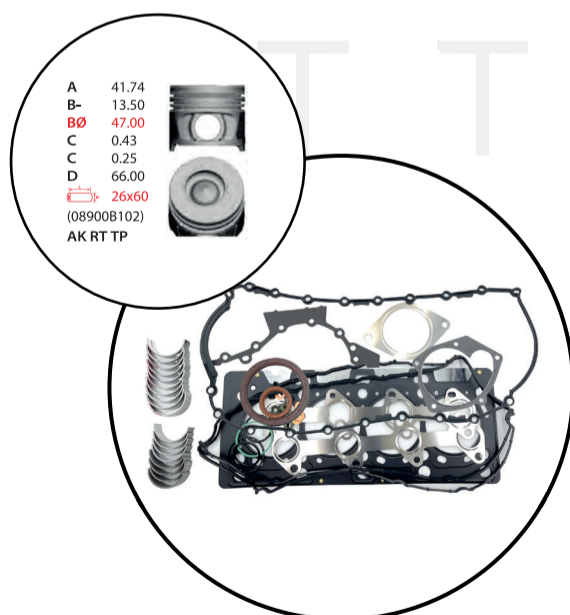

RENAULT DIESEL

1.5 cc

4 cilindri diam.76

KIT3K9K

kit composto da: pistoni 0.50, bronzine banco e biella std, serie guarnizione motore completa



Motori:

K9K 276, 279, 608, 612, 636, 700, 702, 704, 706, 708, 710, 712, 714, 716, 718, 722, 724, 728, 729, 734, 740, 750, 752, 760, 762, 766, 768, 772, 790, 792, 794, 796, 800, 802, 812, 830, 832, 837, 840, 846, 884

1.9 cc

4 cilindri diam.80

KIT1MEGANE19TDI

kit composto da: pistoni 0.50, bronzine banco e biella std, serie guarnizione motore completa

UNIFICATO

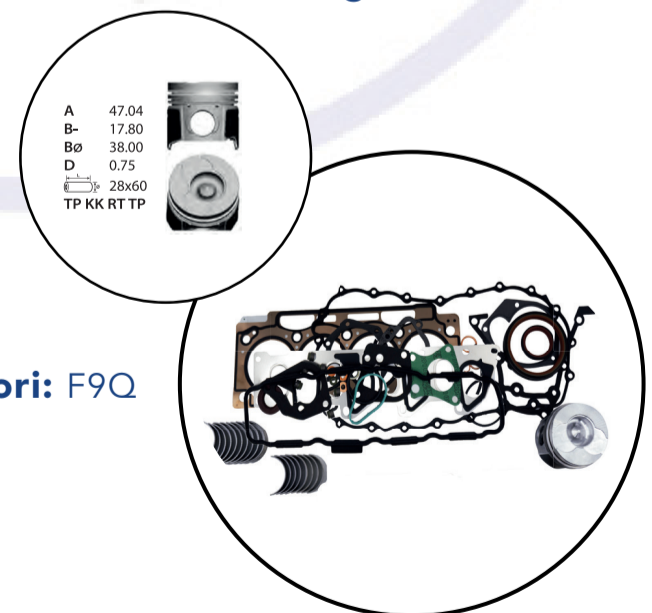

Motori: F9Q

SMART BENZINA

600 cc

3 cilindri diam.63,50

KIT6SMARTBZTR

kit composto da: pistoni 0.25, bronzine banco e biella std, serie guarnizione motore

KIT5SMARTBZTR

kit composto da: pistoni 0.50, bronzine banco e biella std, serie guarnizione motore

Motori:

160.910, M160E6ALB03,
160E6ALB04, M160E6ALB05

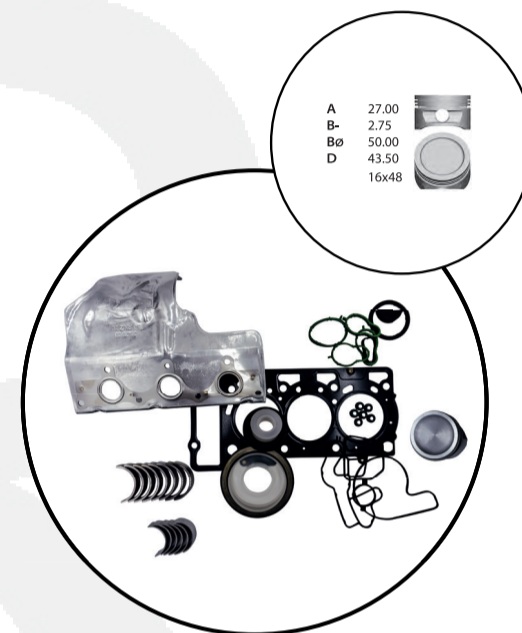

700 cc

3 cilindri diam.66,50

KIT7SMART7BZTR

kit composto da: pistoni 0.25, bronzine banco e biella std, serie guarnizione motore

KIT8SMART7BZTR

kit composto da: pistoni 0.50, bronzine banco e biella std, serie guarnizione motore

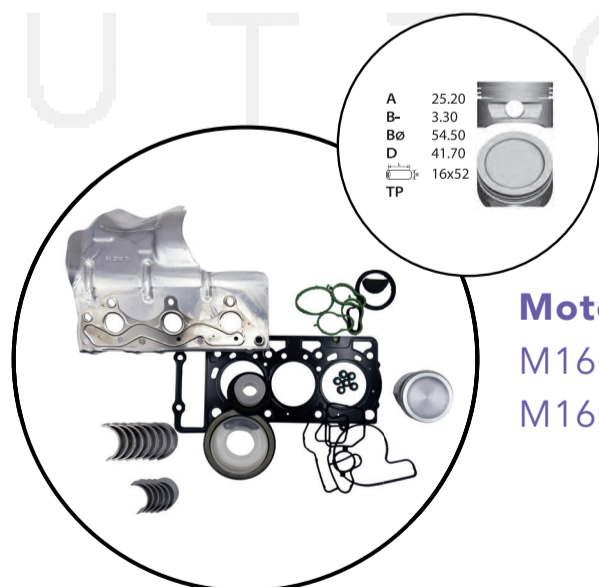

Motori:

M160.920, M160.921,
M160.922, M160.923

SMART BENZINA

700 cc

3 cilindri diam.66,50

KIT11ROADSTER7BZTR

kit composto da: pistoni 0.25, bronzine banco e biella std, serie guarnizione motore

KIT12ROADSTER7BZTR

kit composto da: pistoni 0.50, bronzine banco e biella std, serie guarnizione motore

ROADSTER

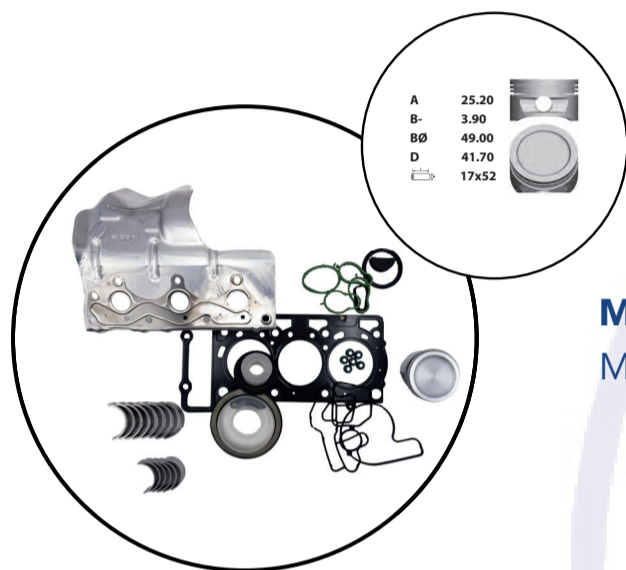

Motori:
M160.920



17.6703



10.6701/2



15.6703



17.6706



15.6701

19.RASSMARTBZ



17.6702 600cc
17.6705 700cc



11.SMARTBZ



01.67001 30x6x89,20
01.67002 25x6x89,50



05.6702 600cc 6PZ



05.6701

05.6703 700cc 6PZ
05.6704 700cc 2PZ



32.6701

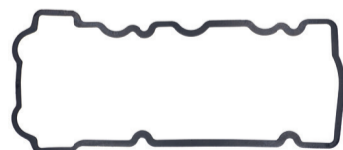

26.6710



05.6705



23.SMART 600cc Ø 63,50 1,2 - 1,5 - 2,5

23.SMART7T1 700cc Ø 66,50 1,2 - 1,5 - 2,5
23.SMART7T2 700cc Ø 66,50 1,2 - 1,2 - 2,5

SMART BENZINA

1.0 cc

3 cilindri diam.72

KITSMART1000/1

kit composto da: pistoni 0.50, bronzine banco e biella std, serie guarnizione motore completa

4 SACCHE VALVOLA

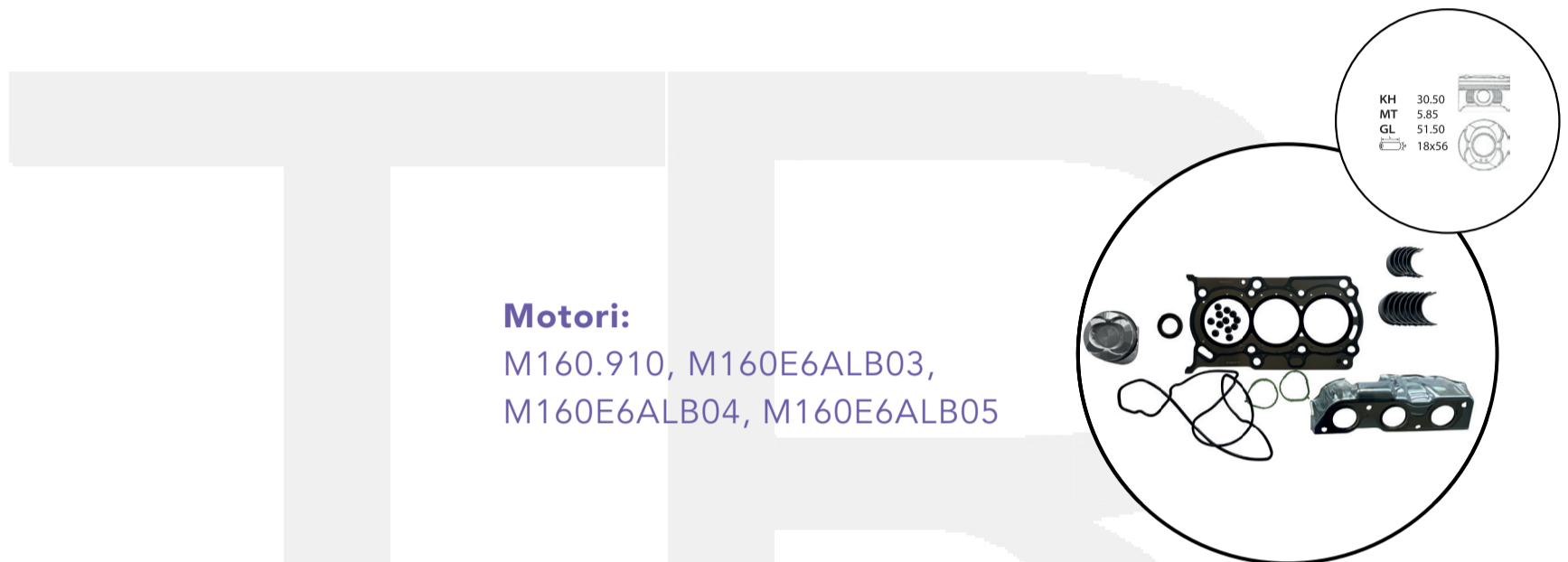

1.0 cc

3 cilindri diam.72

KITSMART1000

kit composto da: pistoni 0.50, bronzine banco e biella std, serie guarnizione motore completa

2 SACCHE VALVOLA

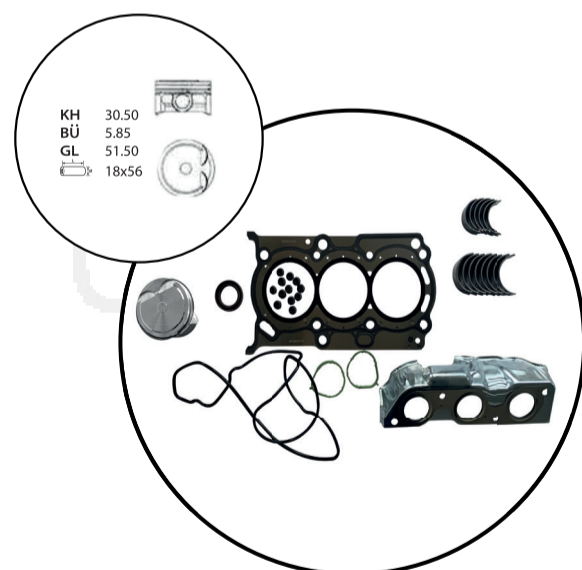

Motori:
M132.910

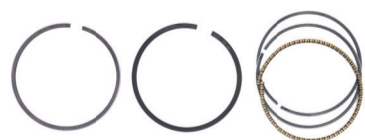

23.SMART1000 1000cc Ø 72 1,0 - 1,2 - 2,0



10.SMART1000



01.67009 28x5x85,45
01.67010 25x5x86,88



19.RASSMART1000



TR
KÖRRTIG®

TUTTORETTICHE®

DA SEMPRE SUL MERCATO

———— **MA MAI VISTA** ————

SCOPRIRE NELLA
PROSSIMA EDIZIONE

SEI INTERESSATO AI NOSTRI SERVIZI?

DOVE CI TROVI

**Via Lombardia, 6
25033 Cologne
Brescia
Italia**

**CONTATTI:
TELEFONO
+39 030 7050590 - 030 7050622**

**AMMINISTRAZIONE
(INT. 1) alessandra.viola@tuttorettifiche.it**

**COMMERCIALE ITALIA
(INT. 3) antonio.viola@tuttorettifiche.it
(INT. 2) lorenzo.viola@tuttorettifiche.it**

**COMMERCIALE ESTERO
(INT. 3) antonio.viola@tuttorettifiche.it**

**MAGAZZINO
(INT. 4) info@tuttorettifiche.it**

**INFORMAZIONI
info@tuttorettifiche.it**

**WHATSAPP
+39 371 5839178**



TR
TUTTORETTIFICHE®